

Gripple Express No.1



The Gripple Express is a fast locking solution for quick and easy suspension of light fixtures, signage, and other lightweight services.

ADVANTAGES

- Up to 6 times faster to install than traditional methods
- Keyless - no tool required for adjustment
- Ergonomic buttons allow rapid adjustment
- Discreet and aesthetic design
- XP1 load rated at 33 lbs with a 5:1 safety factor
- Supplied as a ready-to-use kit

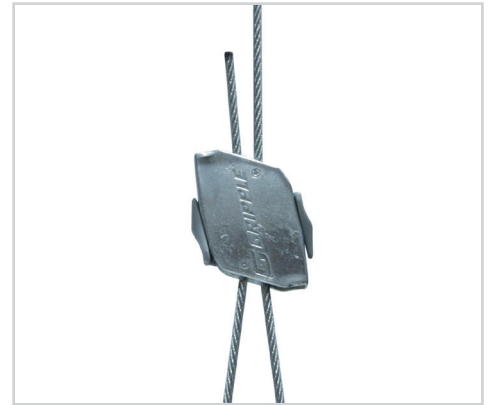

INSTALLATION

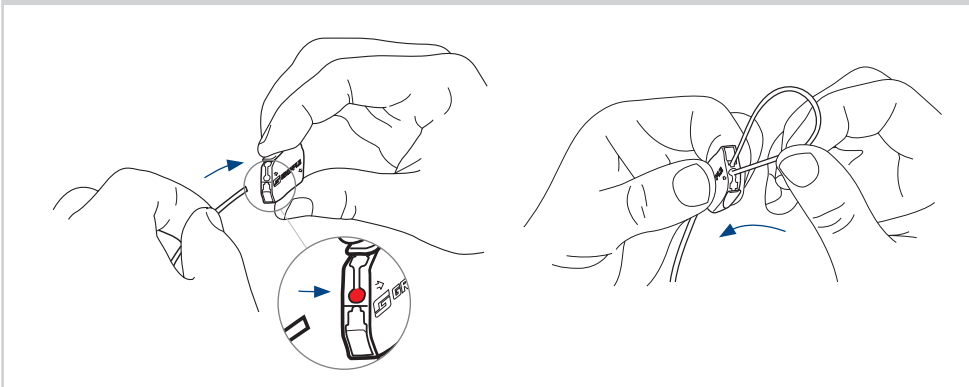

RELEASE

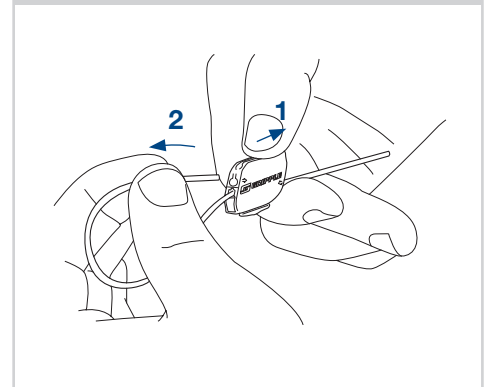

PRODUCT DIMENSIONS

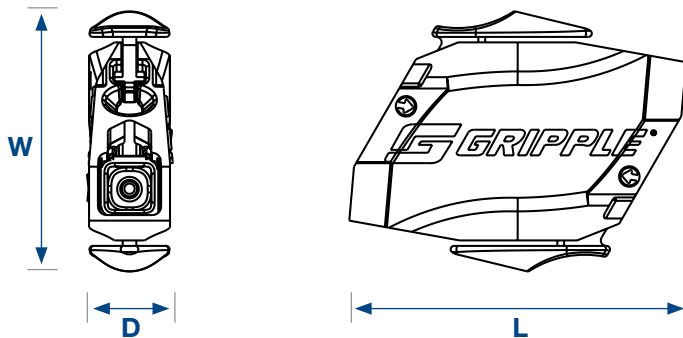

Cable Diameter	L (in)	W (in)	D (in)
1/16"	15/16"	23/32"	7/32"

* This product is silicone free

END FIXING

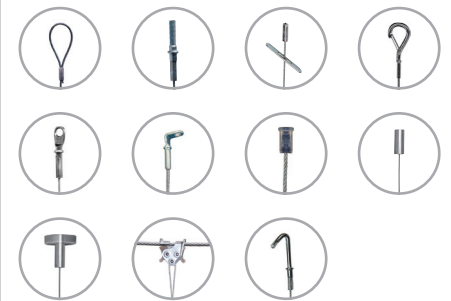

Each ready-to-use kit comes with an end fixing of your choice. Standard hanger lengths are available in 5ft to 30ft lengths; other lengths available upon request.

For further detailed information on any of our end fixings, please visit our website or contact us using the information below.